

2021-2023 Ducati SuperSport 950
Sequential LED Tail Light Installation Guide
Part# D-21SS950-C/S

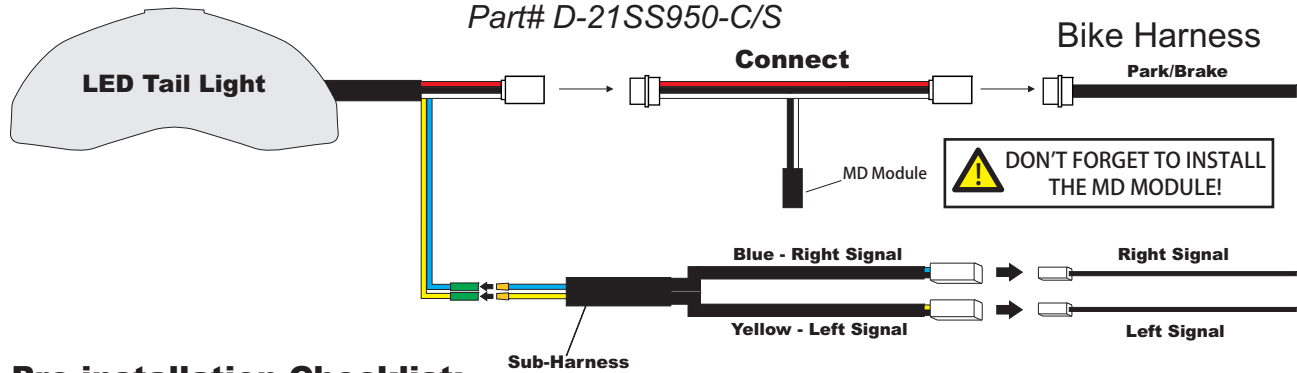

! Pre-installation Checklist:

- Battery is in healthy and fully charged condition - may need engine on after installation to operate signals
- If aftermarket front LED signals are installed:
1. Resistors must be installed on front to slow down the flash rate
- Signals must be flashing at the stock OEM rate prior to install

Park/Brake:

Locate the main 3 wire harness from the bike and connect the MD Module, then connect the other end of the MD Module to the LED tail light.

Wire Schematics:

Black - Ground
Red - Running light
White - Brake light

Sequential Signal:

Using the supplied sub-harness, connect the yellow to yellow and blue to blue wire on the LED tail light. Insulate with green covers. Connect the opposite end of the sub-harness to the bikes factory left and right signal connectors as follows:

'DX' = Yellow/Black

'SX' = Blue/Black

For SuperSport 950 separate the factory fender in half and hidden inside is the harness to connect the turn signals. See illustration below.

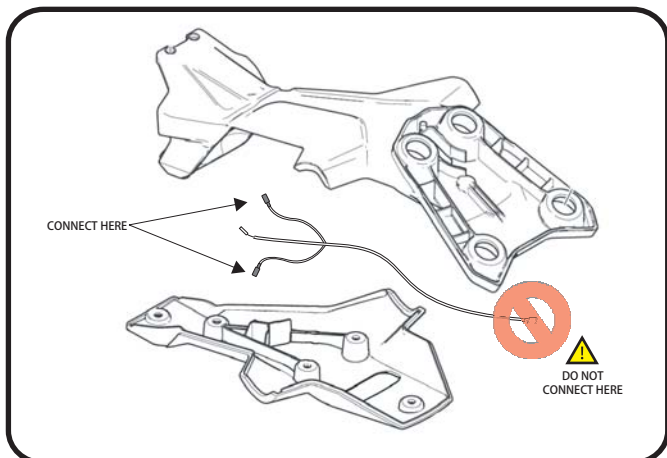

Note:

Two resistors are wired inside the sub-harness. It is normal that these resistors get hot when the turn signals are activated. We recommend to mount onto metal subframe away from soft plastics, toolbags, etc to help dissipate the heat.

Motodynamic Sequential LED Tail Light Programming Instructions

NOTE: It is recommended that the tail light is programmed prior to installation if the button cannot be reached after it is mounted to the bike. Simply connect the main harness to supply power to the tail light while the key is in the "ON" position.

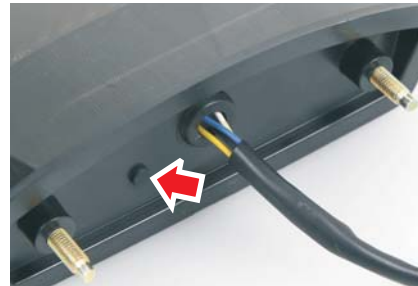

1. Locate the rubber plug on back housing and remove it
2. Turn the key to the "ON" position, making sure the park lights are on
3. Beneath the rubber plug is a push button, use a pin or similar tool to press the button consecutively within 1 second between each press to program the following:

ON/OFF Stop Alert - hit button 3 times
ON/OFF Sequential Signals - hit button 4 times

The parking light (red) will flash off and on again within 2 seconds to verify the settings have been saved. The factory settings are defaulted to ON right out of the box for all functions.

4. Install the rubber plug back into the hole

Note: Turning off Stop Alert will enable the brake light to be constant on during brake activation just like stock. Turning off sequential signals will enable the entire left or right half to turn on when the signals are activated.

*For troubleshoot information please visit:
<http://www.motodynamic.com/faqs>