

2018-2020 Ducati Panigale V4/V2 Fender Eliminator Kit Part No. FE-D18PV4

Parts List

x1 Plate Holder	x1 M5 nylon lock nut
x1 Cover Plate	x4 M6 nylon lock nuts
x1 Wedge Bracket	x1 OEM signal adapter kit
x1 License plate LED light	x2 Aftermarket signal adapters
x1 License light adapter harness	
x6 M5x12mm allen bolts	Required
x4 M6x16mm allen bolts	T20 Torx bit
x6 M5 washers	Loctite or thread sealer
x4 M6 large OD washers	

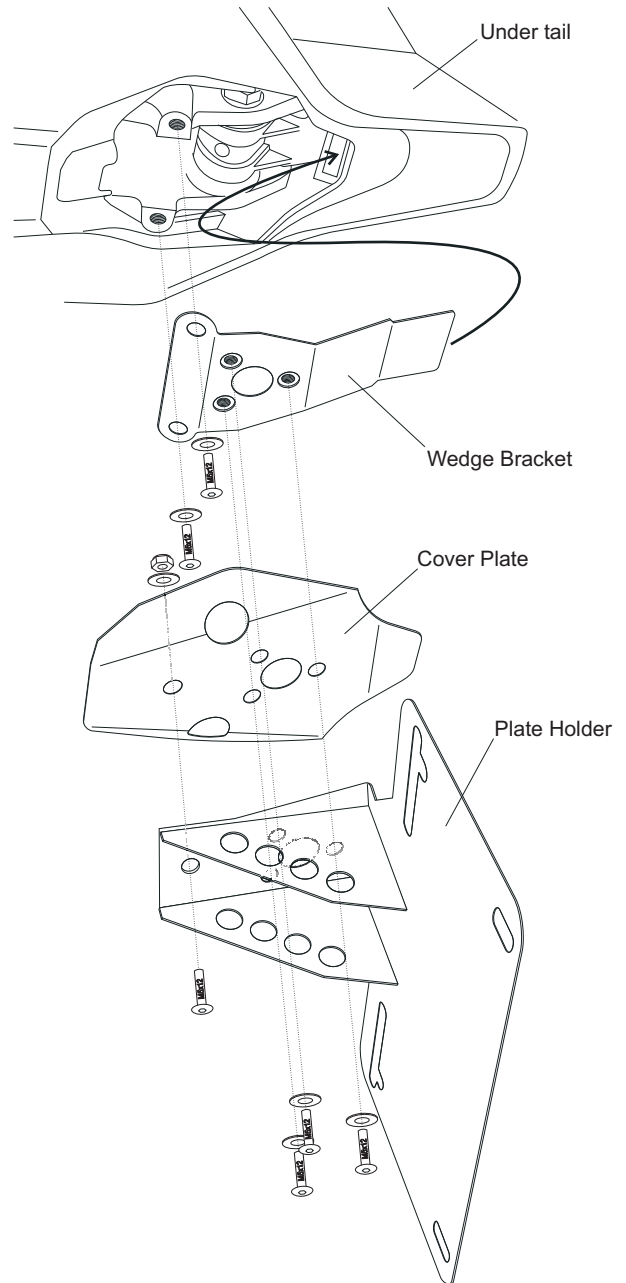

1. Remove lower half of factory rear fender (4 T20 Torx bolts from underneath) and carefully lower down
2. Unplug left and right turn signals connectors as well as the license plate light connector, pop off and cut the wire harness holder cable tie to completely drop the lower half
3. Remove upper half of factory fender (2 bolts from underneath) then pull down and slide forward. Un-route the wire harness through to completely remove
4. Tuck the excess harness slack back into the undertail, leaving exposed the left/right turn signals and license plate light plugs
5. Feed the left/right signal and license plate light plugs (from step above) through the large central round hole on the Wedge Bracket and mount up into the undertail (wedge into the rubber slot) and secure using two (2) M5x12mm bolts and M5 washers. Apply a drop of Loctite or thread sealer on these bolts. See illustration to right
6. Mount the Plate Holder to the Cover Plate using one (1) M5x12mm bolt, M5 washer, and M5 lock nut. Make sure to align the corresponding holes on the Plate Holder to the Cover Plate before tightening. See illustration to right
7. Mount the LED license plate light by feeding the wires one at a time through the center hole, ensuring the LEDs are facing downwards. Then attach the license plate light adapter harness (White>Yellow and Black>Blue). Feed up through the larger central hole on the Plate Holder/Cover Plate assembly

Optional: Mount turn signals (see below)

8. While supporting the Plate Holder/Cover Plate assembly, connect the left/right turn signals and license plate light and mount the assembly to the Wedge Bracket using three (3) M5x12mm bolts and M5 washers. Apply a drop of Loctite or thread sealer on these bolts. Push any remaining wire slack up through the large central hole. See illustration to right
9. Mount the license plate to the plate holder using four (4) M6x16mm bolts, M6 large OD washers, and M6 lock nuts
10. Check all lighting and go on a road test

Installing with factory rear turn signals

1. Remove the factory turn signals off the factory rear fender. Remove the rubber necks off the turn signals (1 bolt - retain bolt for mounting later). See illustration to right for mounting to the turn signal bracket
2. Mount the entire assembly behind the license plate holder using same holes for the license plate
3. Route the wires through the large central opening. Take note that 'DX' = Right and 'SX' = Left

Installing with aftermarket 10mm hole mount turn signals

1. Mount the 2 aftermarket turn signal adapters to the license plate holder upper hole.
2. Mount the aftermarket 10mm hole mount turn signals to adapter
3. Run the wires through the large central opening and wire it to the bike

