

# 2010-2013 Kawasaki Z1000 & 2011-2016 Ninja 1000 Fender Eliminator Kit

[Version 1.2]

## Parts List

- x1 Fender eliminator assembly
- x1 License plate LED light
- x1 License plate harness adapter
- x4 M6x16mm bolts
- x8 M6 nylon lock nuts
- x8 M6 washers
- x2 Factory signal adapters (For USA/Similar models)
- x2 Aftermarket signal adapters

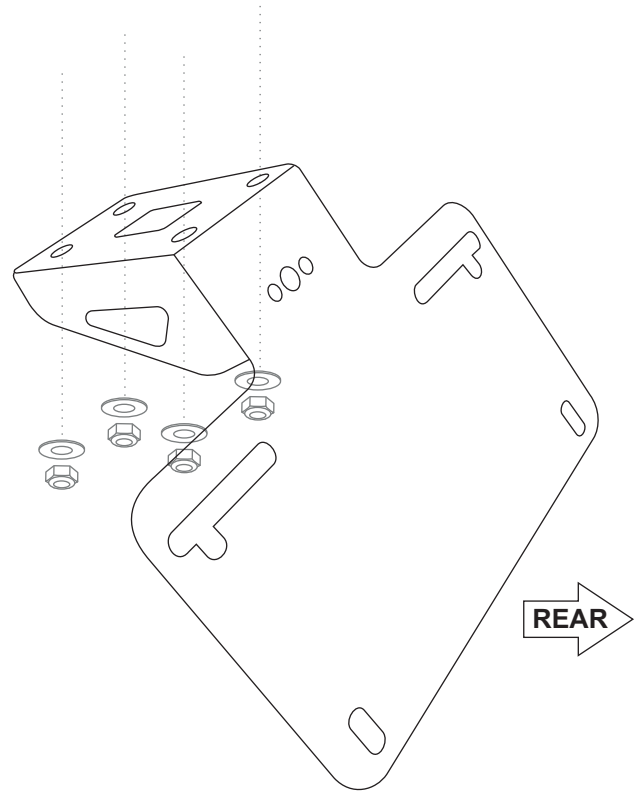

1. Remove both passenger and rider seat.
2. Disconnect license plate light and turn signal wires.
3. Remove four (4) bolts and two (2) screws holding the factory rear fender to the sub chassis. Keep these bolts you will reuse them later.
4. Mount the license plate LED light to fender eliminator assembly and run the wire through to the top square hole. Connect the plug and play license plate harness adapter. **White>White** and **Black>Black**
5. Mount the fender eliminator assembly to the sub chassis using the 4 bolts from step 3 with the 4 lock nuts and washers supplied with the kit.
6. Plug in the license plate harness to the bike. Turn key to test before final assembly
7. Mount the license plate using the four M6x16mm bolts, washers, and lock nuts

## Installing with factory rear turn signals (for USA/Similar models)

1. Disassemble the rear fender from step 3 above (unbolt lower reflector and 2 screws from the side) and remove the factory turn signals
2. Mount the 2 factory turn signal adapters to the fender eliminator assembly plate mount upper hole.
3. Install the factory turn signals in the same method it was removed from the factory fender.
4. Run the 2 turn signal wires through the square hole and connect it back to the bike.

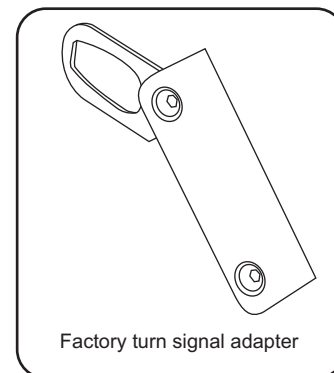

Factory turn signal adapter

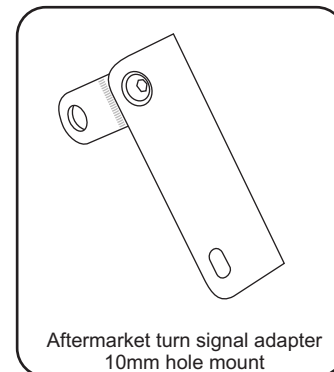

Aftermarket turn signal adapter  
10mm hole mount

## Installing with aftermarket 10mm hole mount turn signals

1. Mount the 2 aftermarket turn signal adapters to the fender eliminator assembly plate mount upper hole.
2. Mount the aftermarket 10mm hole mount turn signals
3. Run the wires through the square hole and wire it to the bike