

Honda Grom 2014-2015, 2017-2019 Sequential LED Tail Light V2 Installation Guide Part# H-14GRM-V2-C/S

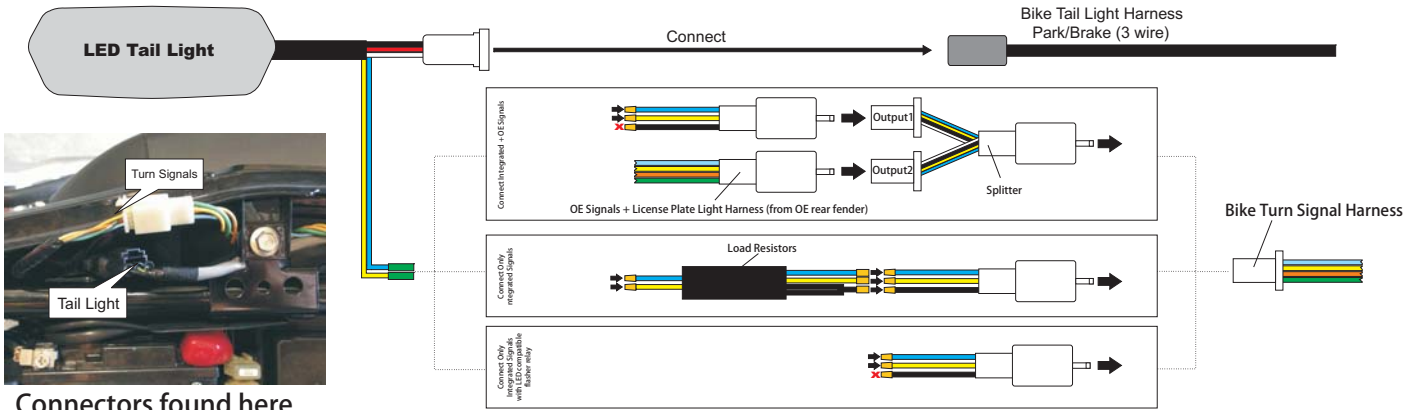

Pre-installation Checklist:

- Battery is in healthy and fully charged condition - may need engine on after installation to operate signals
- If aftermarket front LED signals are installed:
 1. Resistors must be installed on front to slow down the flash rate (or install LED flasher relay)
 2. Disable any running/park lights if available
- Signals must be flashing at the stock OEM rate prior to install

Park/Brake:

Locate the main 3 wire harness from the bike and connect with the 3 wire connector on the LED tail light.

Wire Color Schematics (if needed):

- Red Wire - Park (+)
- White Wire - Brake (+)
- Black Wire - Ground (-)

Turn Signals (pick one):

1. Connecting Integrated + OE Signals: Disconnect the load resistor from the sub-harness. Connect blue and yellow wire to blue and yellow wire on tail light. Omit the black wire. Connect the other end to the Splitter output1. Connect Splitter to bikes turn signal output harness. Locate OE signal and license plate light harness and connect to Splitter output2.

2. Connecting Only Integrated Signals: (fender elimination recommended) Connect the sub-harness blue and yellow to the blue and yellow on the tail light. Connect the other end to the bikes harness.

3. Connecting only integrated signals with LED compatible flasher relay (fender eliminator recommended) Disconnect the load resistor from the sub-harness. Connect blue and yellow wire to blue and yellow wire on tail light. Omit the black wire. Connect the other end to the bike's turn signal output connector

Note:

Two resistors are wired inside the sub-harness. It is normal that these resistors get hot when turn signals are activated. We recommend to mount on subframe in an area with sufficient cooling away from soft plastics, tool bags, etc.

Motodynamic Sequential LED Tail Light Programming Instructions



1. Locate the programming button on back housing
2. Turn the key to the "ON" position, making sure the park lights are on
3. Press the button consecutively within 1 second between each press to program the following:

- ON/OFF Stop Alert - hit button 3 times
- ON/OFF Sequential Signals - hit button 4 times

The light will automatically flash within 2 seconds to verify the settings have been saved. The factory settings are defaulted to ON right out of the box for all functions

Note: Turning off Stop Alert will enable the brake light to be constant on during brake activation just like stock. Turning off sequential signals will enable the entire left or right half to turn on when the signals are activated.

*For troubleshoot information please visit:
<http://www.motodynamic.com/faqs>