

Skid Plate + Oil Cooler Guard Triumph Bonneville/Thruxton/Scrambler

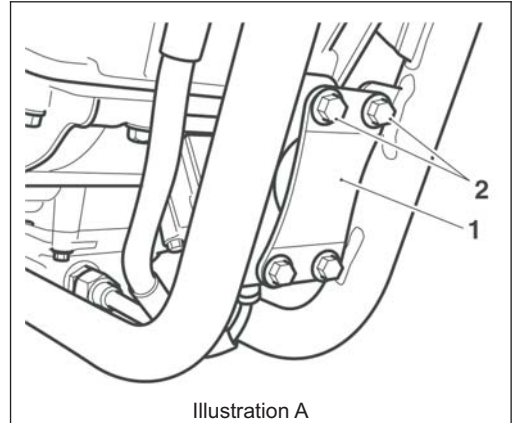
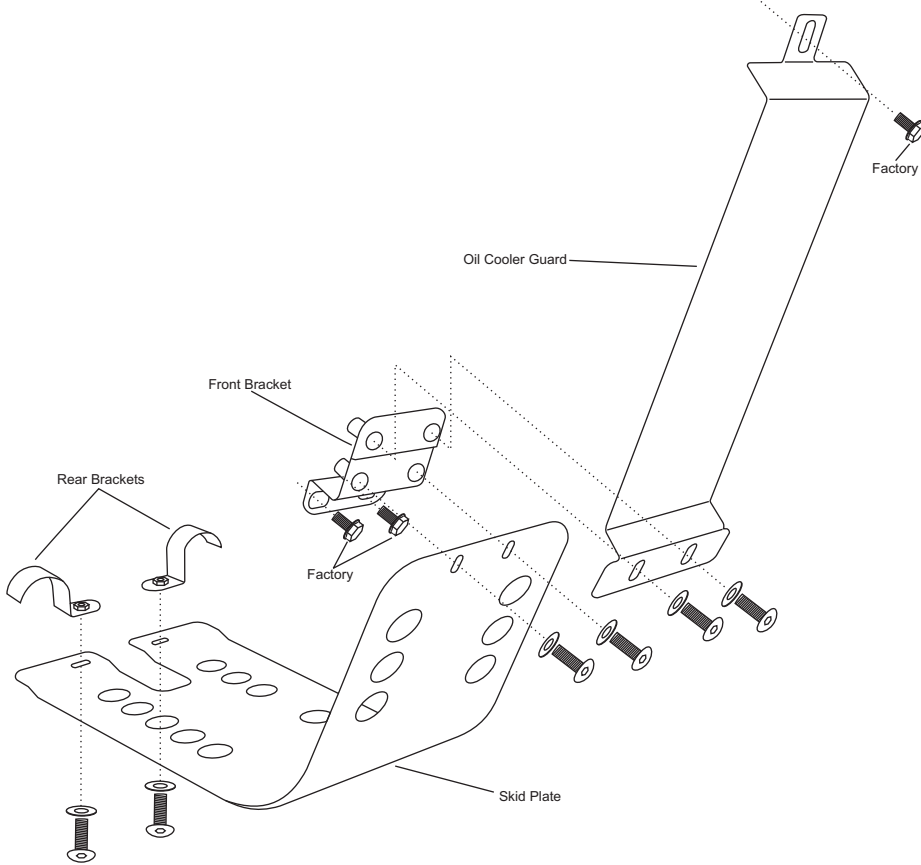

Illustration A

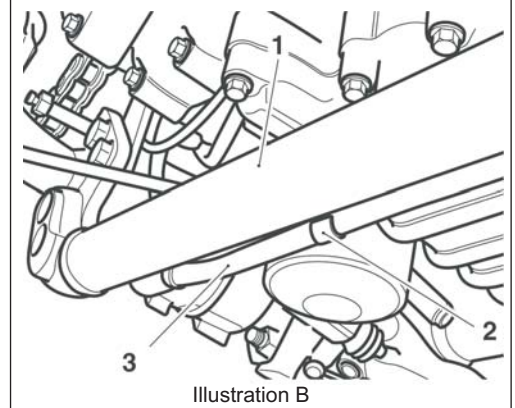

Illustration B

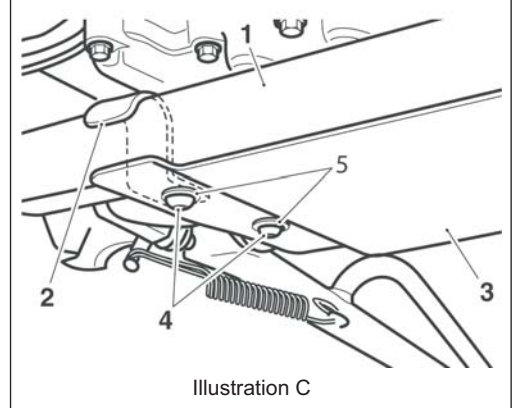

Illustration C

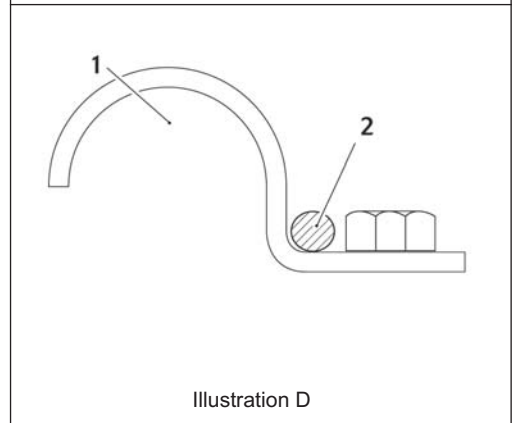

Illustration D

1. Remove the seat and disconnect the negative battery terminal
2. Locate the front chassis brace and remove the upper 2 bolts. See illustration A (Item #1 and #2). Retain these for reuse later
3. Attach the front bracket to the upper 2 holes from step 1 using the same bolts
4. Locate the starter motor lead (wire) and unhook it from the center clip, then remove the clip. See illustration B (item #2 and #3). You no longer need this clip
5. Place the 2 rear brackets above the 2 chassis tubes. See illustration C (Item #1 and #2)
6. Install the Skid plate and mount to the front bracket using the two M6x16mm bolts/washers and the rear brackets using the two M6x10mm bolts/washers
7. Take caution not to crush the starter motor wire. Carefully route wire. See illustration D (Item #1 and #2)
8. Remove the horn assembly, retain bolt
9. Remove bolt behind horn. Install oil cooler guard in between oil cooler and spring clip. Install the bolt back and reinstall the horn assembly
10. Attach the lower section of the oil cooler guard to the uppermost holes on the front bracket
11. Connect negative terminal on battery



The skid plate kit does not provide complete protection from damage to the underside of the motorcycle. Care must be taken to avoid contact between the underside of the motorcycle and any hard or sharp objects. Damage to the underside of the motorcycle may occur if it is allowed to come into contact with any hard or sharp objects.